



# PLASTIC BOTTLE BLOW MOLDING AUTOMATION

## Sidel® Series1 Machines

# Series1 Machine Transfer Arm

*Provides Significantly Longer Life  
Reduces Maintenance and Downtime*



## BENEFITS

- Internal jaw springs positioned in-line between the bearings of each jaw improve the life of the unit. Jaw forces are uniform with regard to the jaw bearings, pins, spring, and gripper head.
- The in-line jaw spring is manufactured especially for PHD and is designed for over 100 million cycles.
- The unit is designed to operate for 20 million cycles.
- The gripper head is high strength aluminum to reduce moving mass.
- Lighter in overall weight than the competitor's unit.
- Jaws incorporate shock pads on close to reduce impact loads and extend life.
- The gripper head is a lower profile design and fits Sidel® Series1 machines; 2420, 2424, 2426, and 4040.
- The pins that hold the jaws in the gripper body are close tolerance, hardened and ground stainless steel.
- Ground profile rail and recirculating ball bearings provide the linear movement of the gripper body assembly.
- All steel parts are chromium/nickle plated to prevent rusting, FDA approved, and provide a very hard slick surface.
- A Transfer Arm Exchange Program is available. Contact PHD for details.
- A Quick Release Finger Kit is available. Ask for kit # 304636-32.

## ORDERING DATA

### TO ORDER SPECIFY:

Base Number, Type, and Machine Number.

**ML 305823 - C - 2**

BASE NUMBER	TYPE	MACHINE NUMBER
Sidel® Series1 Transfer Arm	C - Cold Set H - Heat Set	2 - Most Sidel® Series1 machines 4 - Machine 4040 Consult PHD for other machines.

## FEATURES

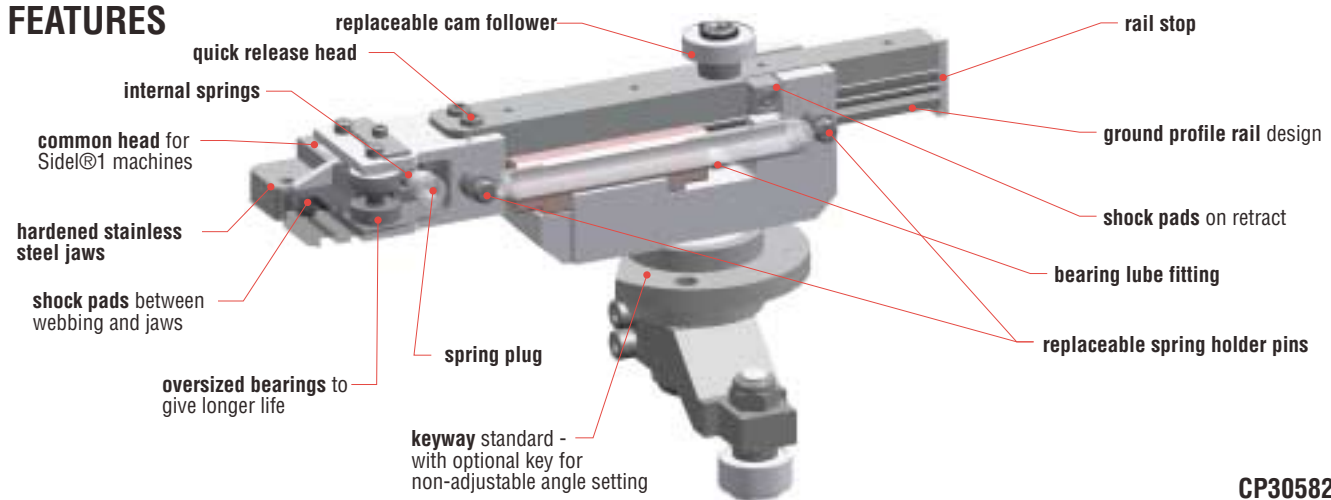

CP305823



# DIMENSIONS: SIDEL® SERIES1 TRANSFER ARM

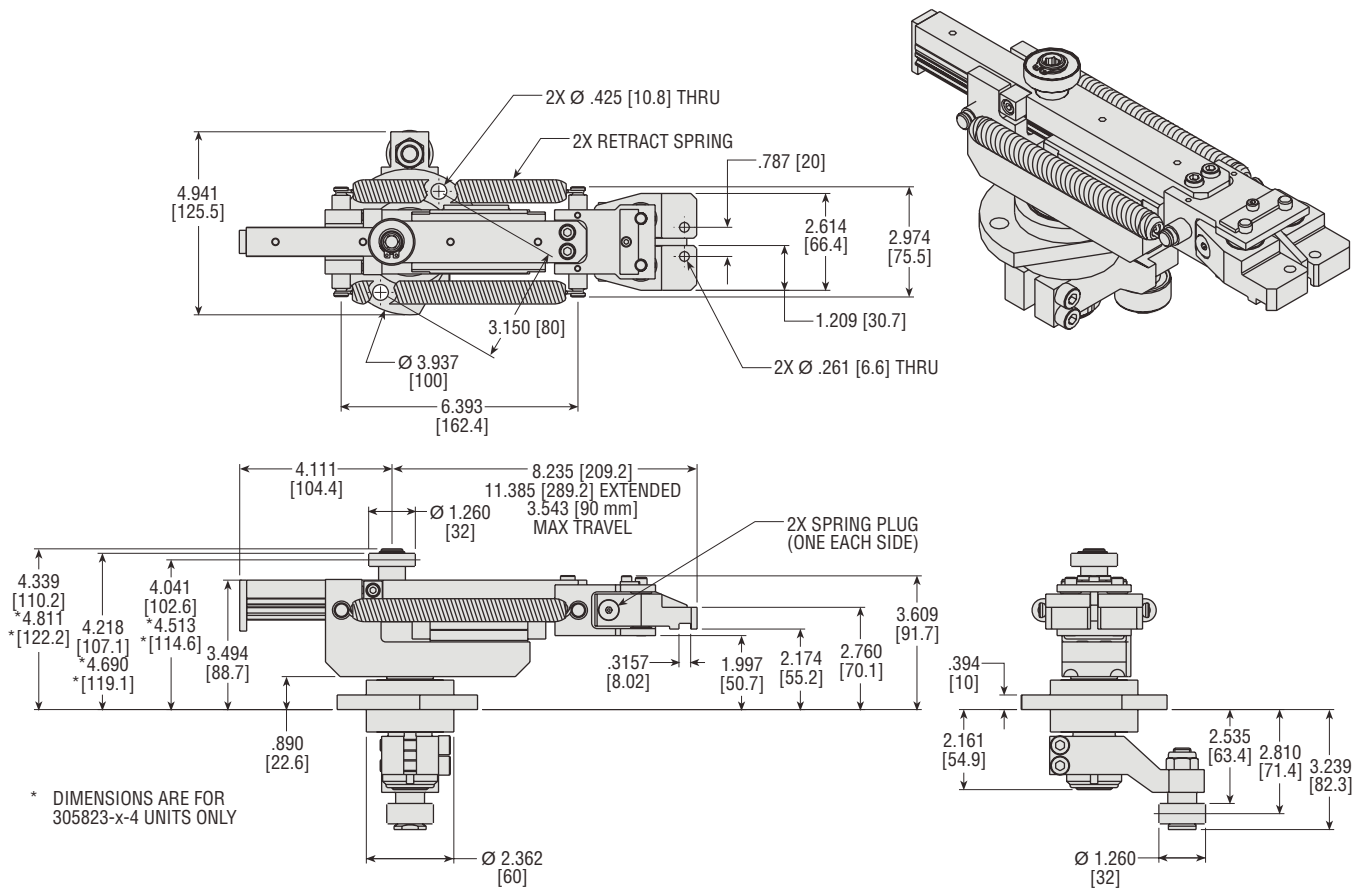

## NOTES:

- 1) UNIT INCORPORATES A SINGLE INTERNAL SPRING BETWEEN THE TWO JAWS AND ON CENTER OF THE JAW BEARINGS (NOT SHOWN)
- 2) ALL DIMENSIONS ARE FOR REFERENCE ONLY
- 3) TO CHANGE SPRINGS, REMOVE SPRING PLUG ON EITHER SIDE
- 4) JAW ROTATION IS A TOTAL OF 30°, 15° EACH JAW

## APPLICATION INFORMATION FOR PHD TRANSFER ARM

Please note the following data for your information and consideration when specifying the PHD Transfer Arm.

- Depending on your specific preform/bottle size, adjustment may be required on the bottle exit guide to insure bottles are properly ejected out of the fingers. The potential need for this adjustment is due to the PHD transfer arm's improved design that provides higher precision, extended life and reduced maintenance. Due to the robust design of the PHD transfer arm head, the jaws open 30 degrees (15 degrees per side), whereas the Sidel® unit opens approximately 180 degrees (90 degrees per side).
- Spring "quick release" tooling (Kit # 304636-32) on the jaw allows the finger to be rotated 180 degrees or more providing clearance for set-up. However, this cannot be done with the transfer arm located above the mold due to clearance. If the transfer arm is over the mold, cycle arm one station over to gain clearance to swivel finger 180 degrees. When set-up is finished, return the jaws to the proper position before cycling the transfer arm over the mold to insure that the jaw tooling does not hit the mold.

SPECIFICATIONS	IMPERIAL	METRIC
TYPE	Preform Transfer Arm Slide	
SERIES	Sidel® Series1	
OPERATION	Cam Operated, Spring Return	
MAXIMUM TEMPERATURE	160° F	71° C
JAW CLOSING FORCE		
COLD SET	13 to 17 lbs	58 to 76 N
HEAT SET	22 to 26 lbs	98 to 116 N
OPERATING SPEED (TYPICAL)	7.3 in/sec	185 mm/sec
LUBRICATION	FDA Regulation 21 CFR 1789.3570	
STROKE RANGE, MAXIMUM	3.543 in	90 mm
BASE WEIGHT	9.2 lbs	3.43 kg
BUMPER	Polyurethane	
BODY AND ARM	6061 T6 Aluminum	
GRIPPER	2042-T351 Aluminum	
SPINDLE	Steel	
JAWS	Hardened Stainless Steel	
SLIDE BEARING	Ground Profile Rail	
SPINDLE AND JAW BEARINGS	Sealed Deep Groove Radial Ball	