

**Pneumatic cylinders, piston-Ø 8 – 25 mm**  
**Single acting**  
**according to DIN ISO 6432**

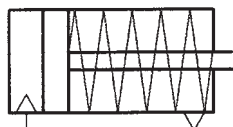

**Technical data for series**

# HE



**Order code**

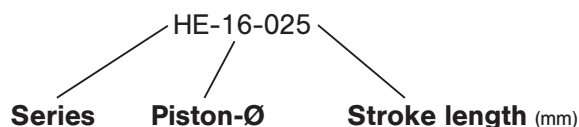

**Design and function**

Single acting pneumatic cylinder with built-in cushioning rings.

Order number Please complete according to order code.	HE-08-...	HE-10-...	HE-12-...	HE-16-...	HE-20-...	HE-25-...
<b>Piston-Ø mm</b>	8	10	12	16	20	25
<b>Connection</b>	M5 (10/32 UNF)				G 1/8	G 1/8
<b>Piston rod thread</b>	M4	M4	M6	M6	M8	M10 x 125
<b>Operating pressure</b>	2 ... 10 bar (29 ... 145 psi)					
<b>Temperature range</b>	- 30 °C ... + 80 °C (- 22 °F ... + 176 °F)					
<b>Medium</b>	filtered/lubricated or filtered/non-lubricated air					
<b>Standard stroke lengths (mm)<sup>1)</sup></b>	10, 25, 50, max. 50					
<b>Materials</b>	Cylinder tube: stainless steel End caps: Al (anodized) Piston rod: stainless steel Seals: PU					

<sup>1)</sup> = refer to "Critical Load Diagram" on page 8.240 to determine critical values on the piston rod.

**Pneumatic cylinders, piston-Ø 8 – 25 mm**  
**Single acting**  
**according to DIN ISO 6432**



**Technical data**

**Force chart for series HE**

Piston-Ø		stroke 10		stroke 25		stroke 50	
		Min.	Max.	Min.	Max.	Min.	Max.
Ø 8	Extension	19.0	19.7	19.0	20.3	19.0	21.7
	Retraction	4.5	5.2	3.9	5.2	2.5	5.2
Ø 10	Extension	36.0	36.7	36.0	37.3	36.0	38.7
	Retraction	4.5	5.2	3.9	5.2	2.5	5.2
Ø 12	Extension	51.7	52.0	51.7	52.6	51.7	53.6
	Retraction	5.7	6.0	5.1	6.0	4.1	6.0
Ø 16	Extension	87.5	90.0	87.5	93.5	87.5	99.7
	Retraction	15.0	17.5	11.5	17.5	5.3	17.5
Ø 20	Extension	142.8	145.0	142.8	148.3	142.8	153.8
	Retraction	21.3	23.5	18.0	23.5	12.5	23.5
Ø 25	Extension	243.7	245.0	243.7	247.0	243.7	250.3
	Retraction	18.2	19.5	16.2	19.5	12.9	19.5

Pressure 6 bar. The internal friction is considered.

**Dimensions for series**

**HE**

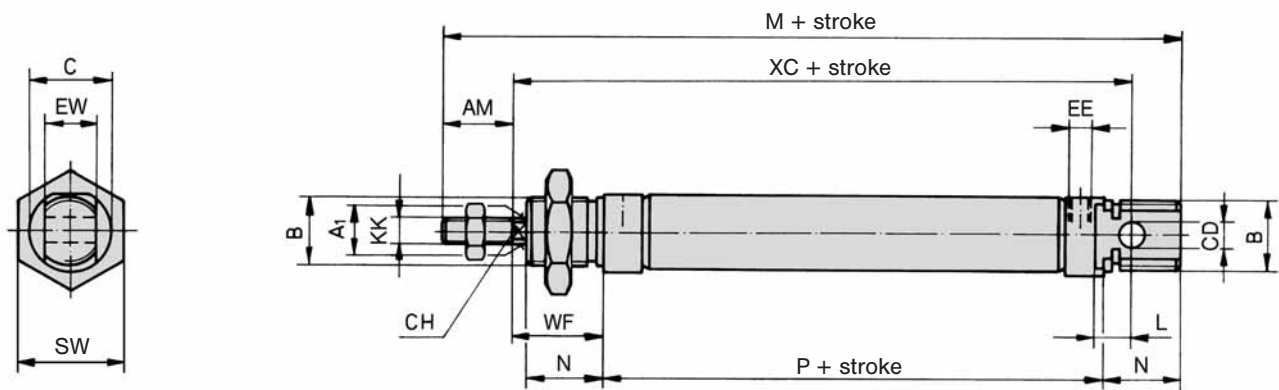

Ø	A <sup>1</sup>	AM	B	C	CD	CH	EE	EW	KK	L	M	N	P	SW	WF	XC
8	4	12	M 12 x 1,25	16	4	-	M5	8	M4	6	86	12	46	19	16	64
10	4	12	M 12 x 1,25	16	4	-	M5	8	M4	6	86	12	46	19	16	64
12	6	16	M 16 x 1,5	19	6	5	M5	12	M6	9	104	18	48	22	22	75
16	6	16	M 16 x 1,5	19	6	5	M5	12	M6	9	109	18	53	22	22	82
20	8	20	M 22 x 1,5	27	8	7	G 1/8	16	M8	12	131	20	67	27	24	95
25	10	22	M 22 x 1,5	30	8	9	G 1/8	16	M10 x 1,25	12	140	22	68	27	28	104

H 9

d 13

Accessories for series

# HE, HM

## Piston rod accessories



Rod eye  
**RO-**  
Page 8.203



Flexible coupling  
**FK-**  
Page 8.203



Rod clevis with pin  
**RD-**  
Page 8.202



Piston rod nut  
**RL-**  
Page 8.202

## Mounting accessories



Foot mount  
Ø 8 – 25  
**RA-**  
Page 8.086



Foot mount  
Ø 32 – 63  
**RA-**  
Page 8.086



Clevis mount  
Ø 8 – 63  
**RC-**  
Page 8.087



Threaded bolts  
Ø 32 – 63  
**RG-**  
Page 8.087

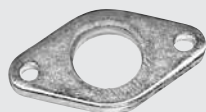

Flange mount  
Ø 8 – 25  
**RB-**  
Page 8.086



Mounting nut  
Ø 8 – 25  
**RM-**



Mounting nut  
Ø 32 – 63  
**RM-**

Accessories for series

# HM

Proximity sensors

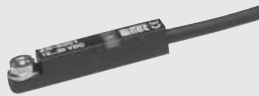

Sensors  
**ZS-**  
Page 8.220



Mounting bracket  
**NT-**  
Page 8.221



Connecting cable  
**KA-**  
Page 8.221

Linear guides

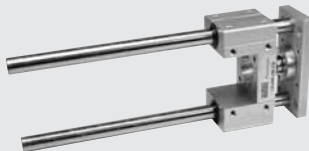

Linear guides  
**LE-**  
Page 8.180

Piston-Ø	Foot mount	Clevis mount	Threaded bolts	Flange mount	Sensors	Mounting bracket	Rod clevis	Flexible coupling	Rod eye	Mounting nut	Piston rod nut
8	RA-10	RC-10	-	RB-10	ZS-5200	NT-0810	RD-10	-	-	RM-10	RL-10
10	RA-10	RC-10	-	RB-10			RD-10	-	-	RM-10	RL-10
12	RA-16	RC-16	-	RB-16	ZS-5300	NT-1216	RD-16	FK-16	RO-16	RM-16	RL-16
16	RA-16	RC-16	-	RB-16	ZS-5300-05		RD-16	FK-16	RO-16	RM-16	RL-16
20	RA-25	RC-30	-	RB-25	ZS-5301	NT-2025	RD-20	FK-20	RO-20	RM-25	RL-20
25	RA-25	RC-30	-	RB-25			RD-25	FK-32	RO-25	RM-25	RL-25
32	RA-32	RC-32	RG-32	-	ZS-6300	NT-0032	RD-32	FK-33	RO-32	RM-32	RL-32
40	RA-40	RC-40	RG-40	-	ZS-6301	NT-0040	RD-40	FK-41	RO-40	RM-40	RL-40
50	RA-50	RC-50	RG-50	-	ZS-7300	NT-0050	RD-63	-	RO-50	RM-63	RL-63
63	RA-63	RC-63	RG-63	-	ZS-7301	NT-0063	RD-63	-	RO-50	RM-63	RL-63

For piston-Ø 8, 10 and 12 mm only electronic switches (ZS-6300, ZS-6301, ZS-7000 or ZS-7001) can be used.

## Accessories

### Mounting accessories for series

# HE, HM

#### Foot mount

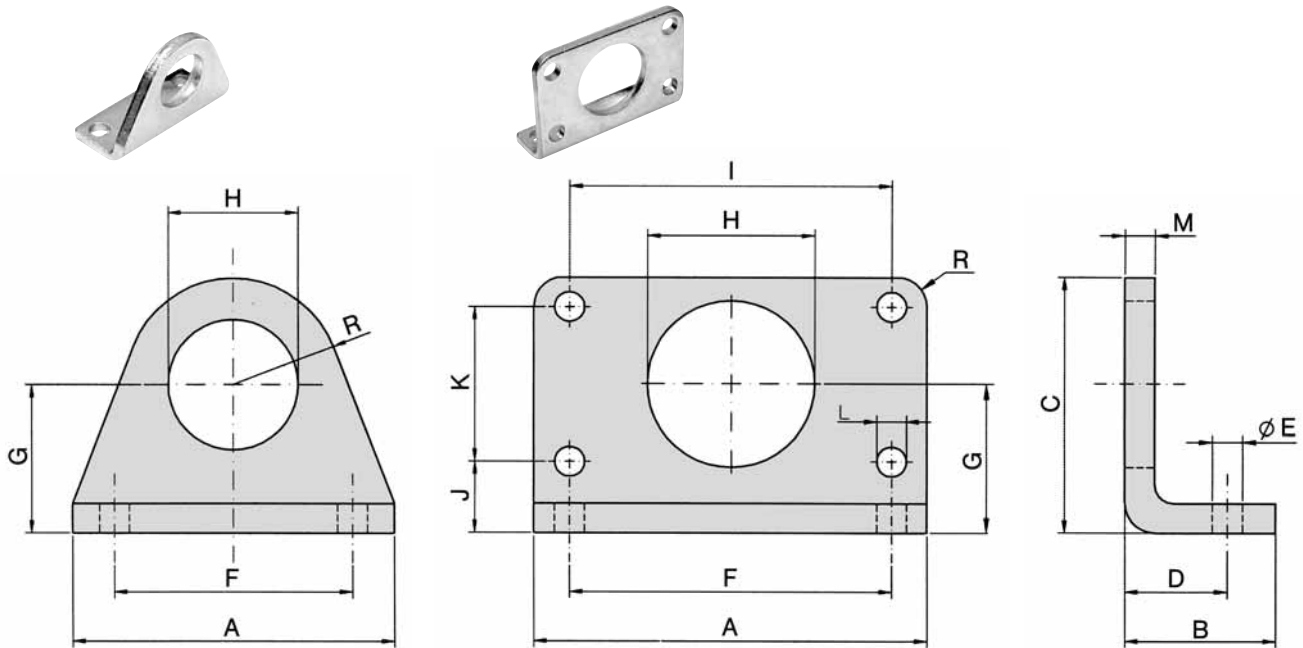

Material: steel (zinc-plated)

Order number	A	B	C	D	E	F	G	H	I	J	K	L	M	R
RA-10	35	16	26	11	4.5	25	16	12	-	-	-	-	3	10
RA-16	42	20	32.5	14	5.5	32	20	16	-	-	-	-	4	12.5
RA-25	54	25	45	17	6.6	40	25	22	-	-	-	-	5	20
RA-32	66	21	49	14	7	52	28	30	52	14	28	7	4	-
RA-40	80	30	58	20	9	60	33	38	60	18	30	9	5	-
RA-50	90	30	70	20	9	70	40	45	70	20	40	9	6	-
RA-63	96	30	80	20	9	76	45	45	76	20	50	9	6	-

#### Flange mount

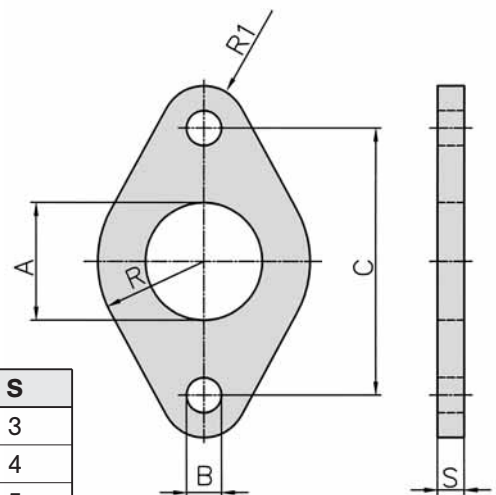

Material: steel (zinc-plated)

Order number	A	B	C	R	R <sub>1</sub>	S
RB-10	12	4.5	30	11	5	3
RB-16	16	5.5	40	15	6	4
RB-25	22	6.6	50	20	8	5

## Accessories

Mounting accessories for series

# HE, HM

Clevis mount  
for  $\varnothing 8 - 25$



$\varnothing 32 - 63$

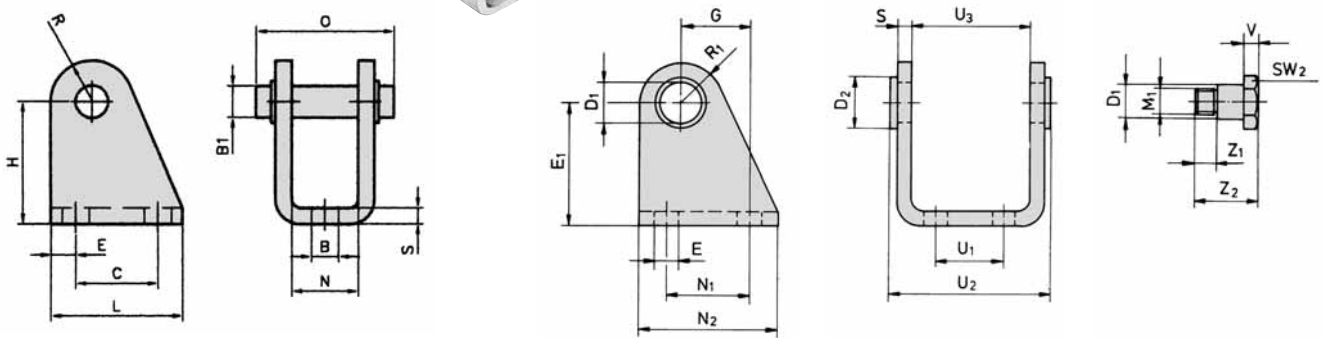

Material: steel (zinc-plated)

Order number	B	B <sub>1</sub>	C	H	L	N	O	R	S	E
RC-10	4.5	4	12.5	24	20	8.1	17	5	2.5	5
RC-16	5.5	6	15	27	25	12.1	23	7	3	5
RC-30	6.6	8	20	30	32	16.1	30	10	4	6

Order number	D <sub>1</sub>	D <sub>2</sub>	E	E <sub>1</sub>	G	M <sub>1</sub>	N <sub>1</sub>	N <sub>2</sub>	R <sub>1</sub>	S	U <sub>1</sub>	U <sub>2</sub>	U <sub>3</sub>	V	Z <sub>1</sub>	Z <sub>2</sub>	SW <sub>2</sub>
RC-32	10	15	7	35	20	M8 x 1	24	40	12	4	20	50.1	38.1	4	6	18	13
RC-40	12	20	9	40	27	M10 x 1	30	50	13	5	28	60.1	46.1	5	7	21.6	17
RC-50	14	23	9	45	30	M12 x 1.5	34	54	14	6	36	74.1	57.1	6	9	26.4	19
RC-63	16	23	9	50	34	M14 x 1.5	35	65	16	6	42	88.1	70.1	6	16	35	19

## Threaded bolts

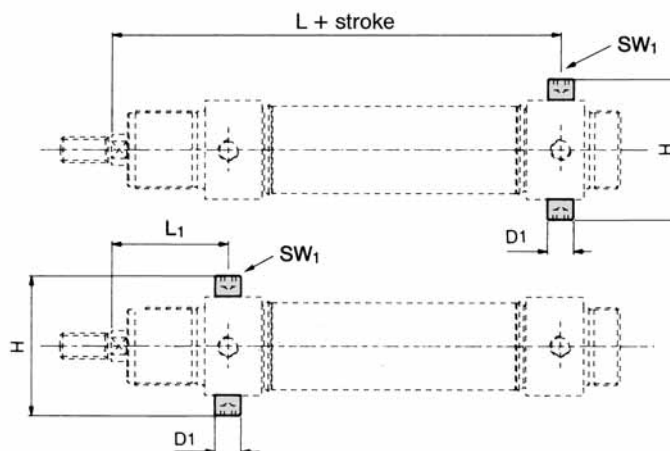

Material: steel (zinc-plated)

Order number	D <sub>1</sub>	H	L	L <sub>1</sub>	SW <sub>1</sub>
RG-32	10	51	125	47	5
RG-40	12	61	146	57	6
RG-50	14	75	158	62	6
RG-63	16	90	162	64	8

## Piston rod accessories

### Assignment to series

Series	Cylinder Ø mm	Piston rod thread	Rod clevis	Piston rod nut	Flexible coupling	Rod eye
HM	Ø 8 and 10	M 4	RD-10	RL-10	-	-
NXD HM	Ø 12 Ø 12 and 16	M 6	RD-16	RL-16	FK-16	RO-16
NXD HM	Ø 16 Ø 20	M 8	RD-20	RL-20	FK-20	RO-20
NXD HM XL	Ø 20 to 40 Ø 25 Ø 32	M 10 x 1.25	RD-25	RL-25	FK-32	RO-25
HM	Ø 32	M 10	RD-32	RL-32	FK-33	RO-32
HM	Ø 40	M 12	RD-40	RL-40	FK-41	RO-40
HM	Ø 50 and 63	M 16	RD-63	RL-63	-	RO-50
NXD XL	Ø 50 and 63 Ø 40	M 12 x 1.25	FD-40	FE-40	FK-40	FO-40
NXD XL	Ø 80 Ø 50 and 63	M 16 x 1.5	FD-63	FE-63	FK-63	FO-63
NXD XL	Ø 100 Ø 80 and 100	M 20 x 1.5	FD-80	FE-80	FK-80	FO-80
XL	Ø 125	M 27 x 2	FD-125	FE-125	FK-125	FO-125
XG	Ø 160 and 200	M 36 x 2	FD-200	FE-200	-	FO-200

### Rod clevis with pin

Order number	A	B	C	D	E	F	G	H
RD-10	M 4	8	16	11,5	4	21	8	4
RD-16	M 6	12	24	16	6	31	12	6
RD-20	M 8	16	32	22	8	42	16	8
RD-25	M 10 x 1.25	20	40	26	10	52	20	10
RD-32	M 10	20	40	26	10	52	20	10
RD-40	M 12	24	48	32	12	62	24	12
RD-63	M 16	32	64	36	16	83	32	16
FD-40	M 12 x 1.25	24	48	32	12	62	24	12
FD-63	M 16 x 1.5	32	64	40	16	83	32	16
FD-80	M 20 x 1.5	40	80	50	20	105	40	20
FD-125*	M 27 x 2	54	110	65	30	148	55	30
FD-200*	M 36 x 2	72	144	84	35	188	70	35

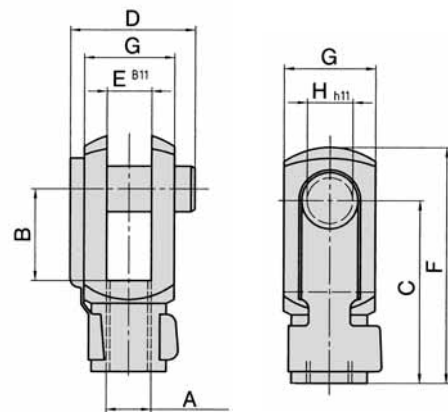

Material: steel (zinc-plated)  
spring steel

\* Bolt with snaprings

### Piston rod nut

Order number	A	B	C
RL-10	M 4	3.2	7
RL-16	M 6	5	10
RL-20	M 8	6.5	13
RL-25	M 10 x 1.25	6	17
RL-32	M 10	6	17
RL-40	M 12	7	19
RL-63	M 16	8	24
FE-40	M 12 x 1.25	7	19
FE-63	M 16 x 1.5	8	24
FE-80	M 20 x 1.5	9	30
FE-125	M 27 x 2	12	41
FE-200	M 36 x 2	14	55

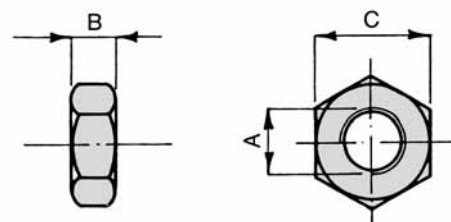

Material: steel (zinc-plated)

# Piston rod accessories

## Flexible coupling

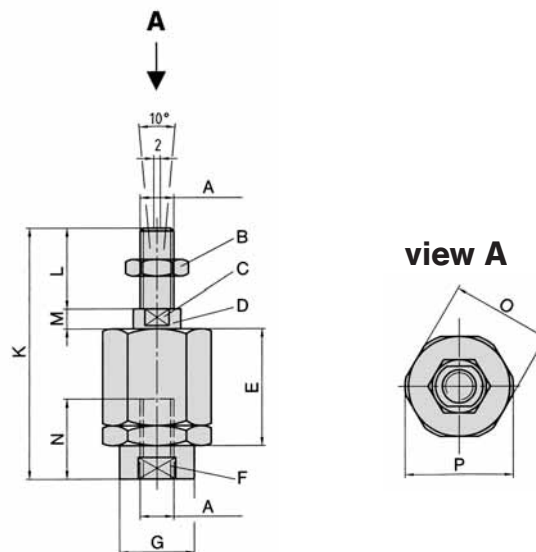

Material: steel (zinc-plated)

Order number	A	B	C	D	E	F	G	K	L	M	N	O	P
FK-16	M6	SW 10	SW 5	6	17.5	SW 7	8.5	35	10	3.5	10	13	15
FK-20	M8	SW 13	SW 7	8	28.5	SW 11	12.5	57	20	4	20	17	19
FK-32	M 10 x 1.25	SW 17	SW 12	14	35	SW 19	22	71	20	5	20	30	32
FK-33	M 10	SW 17	SW 12	14	35	SW 19	22	71	20	5	20	30	32
FK-40	M 12 x 1.25	SW 19	SW 12	14	35	SW 19	22	75	24	5	20	30	32
FK-41	M 12	SW 19	SW 12	14	35	SW 19	22	75	24	5	20	30	32
FK-63	M 16 x 1.5	SW 24	SW 20	22	54	SW 30	32	103	32	8	32	41	45
FK-80	M 20 x 1.5	SW 30	SW 20	22	54	SW 30	32	119	40	8	40	41	45
FK-125	M 27 x 2	SW 46	SW 24	32.2	60	SW 54	57	147	49.5	9.5	40	65	70

## Rod eye

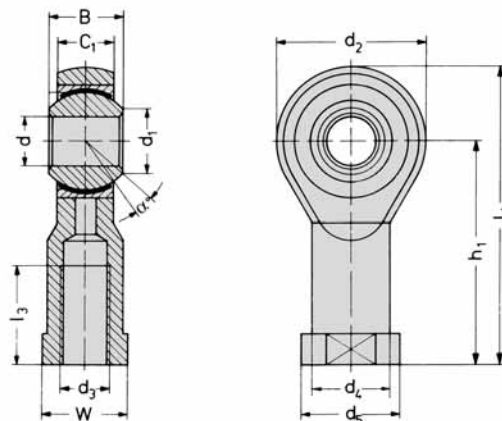

Material: steel (zinc-plated)  
stainless steel

Order number	d <sub>3</sub>	d	d <sub>1</sub>	d <sub>2</sub>	d <sub>4</sub>	d <sub>5</sub>	B	C <sub>1</sub>	W	L <sub>3</sub>	L <sub>4</sub>	h <sub>1</sub>	α
RO-16	M6	6	8.9	20	10	13	9	6.75	11	12	40	30	13
RO-20	M8	8	10.4	24	12.5	16	12	9	13	16	48	36	13
RO-25	M 10 x 1.25	10	12.9	28	15	19	14	10.5	17	20	57	43	13
RO-32	M 10	10	12.9	28	15	19	14	10.5	17	20	57	43	13
RO-40	M 12	12	15.4	32	17.5	22	16	12	19	22	66	50	13
RO-50	M 16	16	19.3	42	22	27	21	15	22	28	85	64	15
FO-40	M 12 x 1.25	12	15.4	32	17.5	22	16	12	19	22	66	50	13
FO-63	M 16 x 1.5	16	19.3	42	22	27	21	15	22	28	85	64	15
FO-80	M 20 x 1.5	20	24.3	50	27.5	34	25	18	32	33	102	77	15
FO-125	M 27 x 2	30	34.8	70	40	51	37	25	41	51	145	110	15
FO-200	M 36 x 2	35	37.7	80	46	56	43	28	50	56	165	125	15

# Proximity sensors

## Wiring diagram

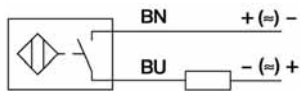

Reed  
**ZS-5200**

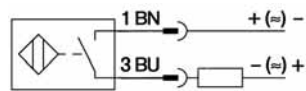

Reed  
**ZS-5201**

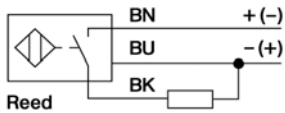

Reed  
**ZS-5300, ZS-5300-05**

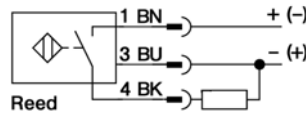

Reed  
**ZS-5301**

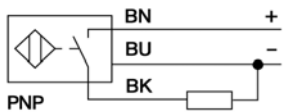

PNP  
**ZS-6300, ZS-7300**

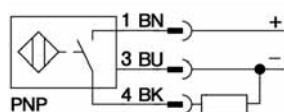

PNP  
**ZS-6301, ZS-7301**

## Dimensions

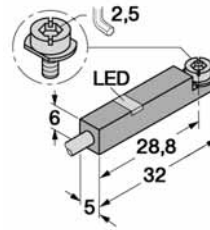

**ZS-5200, ZS-5300,  
ZS-5300-05,  
ZS-6300, ZS-7300**

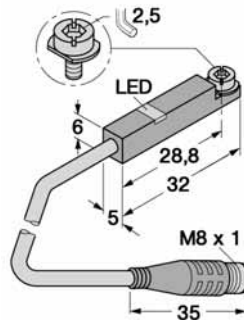

**ZS-5201, ZS-5301,  
ZS-6301, ZS-7301**

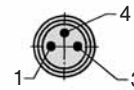

## Function principles

Magnetic field sensors are actuated by magnetic fields and are especially suited for piston position detection in pneumatic cylinders. Based on the fact that magnetic fields can permeate non-magnetizable metals, it is possible to detect a permanent magnet attached to the piston through the aluminum wall of the cylinder.

## Mounting tip

The sensor is firmly fixed in the groove by clockwise rotation of the screw.

Order number	ZS-5200	ZS-5201	ZS-5300	ZS-5300-05	ZS-5301
<b>Design</b>	2-pole Reed sensor (non-polarized) normally open		3-pole Reed sensor* normally open		
<b>Cable</b>	∅ 3, Lif9Y-11Y, PUR		∅ 3, LifYY-11Y, PUR		
<b>Cable cross section</b>	2 x 0.14 mm <sup>2</sup>		3 x 0.14 mm <sup>2</sup>		
<b>Cable length</b>	3 m	0,3 m	3 m	5 m	0,3 m
<b>Cable plug</b>	-	M8	-	-	M8
<b>Overtravel speed</b>	≤ 10 m/s				
<b>Max. absolute hysteresis</b>	≤ 1 mm				
<b>Temperature drift</b>	≤ 0.1 mm				
<b>Min. absolute repeat accuracy</b>	≤ ± 0.1 mm				
<b>Operating temperature</b>	- 25 °C ... + 70 °C				
<b>Degree of protection</b>	IP 67				
<b>Housing material</b>	Plastic PA 12				
<b>Switching status indication</b>	LED yellow				
<b>Rated operational voltage</b>	3 ... 140 VAC / 4 ... 200 VDC		10 ... 30 V DC*		
<b>Rated operational current I<sub>E</sub></b>	DC ≤ 100 mA AC ≤ 100 mA		≤ 500 mA ≤ 500 mA		
<b>Breaking capacity</b>	10 W				
<b>No-load current</b>	0 mA				
<b>Max. OFF-state current</b>	0 mA				
<b>Max. switching frequency</b>	≤ 0.5 kHz				
<b>Rated insulation voltage</b>	≤ 0.5 kV				
<b>Short-circuit protection</b>	no				
<b>Max. voltage drop at I<sub>E</sub></b>	≤ 3 V		≤ 0.5 V		
<b>Wire breakage</b>	no				
<b>Reverse polarity protection</b>	yes				
<b>Vibration resistance</b>	55 Hz (1 mm)				
<b>Shock resistance</b>	30 g (11 ms)				
<b>Explosion proof</b>	-				

\* Useable as 2-wire contact, voltage 0 ... 30 V AC / 0 ... 30 V DC, LED has no function.

## Proximity sensors

### Mounting bracket for round cylinder Ø 8 – 63 mm

Material: PA, steel zinc plated



Order number	Piston-Ø
NT-0810	8 and 10 mm
NT-1216	12 and 16 mm
NT-2025	20 and 25 mm
NT-0032	32 mm
NT-0040	40 mm
NT-0050	50 mm
NT-0063	63 mm

### Connecting cable for ZS-5201, ZS-5301, ZS-6301 and ZS-7301

Cable: PUR, black, 3 x 0,25 mm<sup>2</sup>, ø 3.9, high flexible  
Operating voltage 0 ... 48 V AC/DC

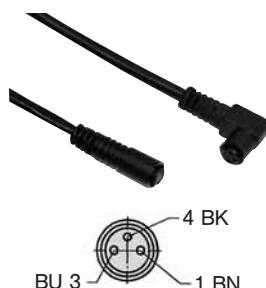

Order number	Length of cable	Connection
KA-30	3 m	8 mm sensor snap-in, straight
KA-50	5 m	8 mm sensor snap-in, straight
KA-51	5 m	8 mm sensor snap-in, 90°
KA-100	10 m	8 mm sensor snap-in, straight
KA-101	10 m	8 mm sensor snap-in, 90°

### Proximity sensors electronic

Order number	ZS-6300	ZS-6301	ZS-7300	ZS-7301
<b>Design</b>	electronic, magnet-inductive sensor, normally open PNP output			
<b>Cable</b>	ø 3, LifYY-11Y, PUR			
<b>Cable cross section</b>	3 x 0.14 mm <sup>2</sup>			
<b>Cable lengths</b>	3 m	0.3 m	3 m	0.3 m
<b>Cable plug</b>	-	M8	-	M8
<b>Overtravel speed</b>	≤ 10 m/s			
<b>Max. absolute hysteresis</b>	≤ 1 mm			
<b>Temperature drift</b>	≤ 0.1 mm			
<b>Min. absolute repeat accuracy</b>	≤ ± 0.1 mm			
<b>Operating temperature</b>	- 25 °C ... + 70 °C			
<b>Degree of protection</b>	IP 67			
<b>Housing material</b>	Plastic, PA 12			
<b>Switching status indication</b>	LED yellow			
<b>Rated operational voltage</b>	10 ... 30 V DC, max. ripple ≤ 10 % U <sub>pp</sub>			
<b>Rated operational current I<sub>E</sub></b>	DC ≤ 200 mA AC -			
<b>Breaking capacity</b>	6 W			
<b>No-load current</b>	≤ 15 mA			
<b>Max. OFF-state current</b>	≤ 0.1 mA			
<b>Max. switching frequency</b>	≤ 1 kHz			
<b>Rated insulation voltage</b>	≤ 0.5 kV			
<b>Short-circuit protection</b>	yes, cyclic			
<b>Max. voltage drop at I<sub>E</sub></b>	≤ 1.8 V			
<b>Wire breakage</b>	yes			
<b>Reverse polarity protection</b>	yes/complete			
<b>Vibration resistance</b>	55 Hz (1 mm)			
<b>Shock resistance</b>	30 g (11 ms)			
<b>Explosion proof</b>	-		II 3 GD EEx nA II T4 X IP 67 T 110 °C	

## Technical charts

This table shows the air consumption for a single stroke of 100 mm. These statements are based upon extension and are in NI.

Piston-Ø mm	Air pressure in bar/psi						
	2 (29 psi)	3 (43.4 psi)	4 (58 psi)	5 (72.5 psi)	6 (87 psi)	7 (101.5 psi)	8 (116 psi)
8	0.02	0.02	0.03	0.03	0.04	0.04	0.05
10	0.02	0.03	0.04	0.05	0.05	0.06	0.07
12	0.03	0.05	0.06	0.07	0.08	0.09	0.10
16	0.06	0.08	0.10	0.12	0.14	0.16	0.18
20	0.09	0.13	0.16	0.19	0.22	0.25	0.28
25	0.15	0.20	0.25	0.29	0.34	0.39	0.44
32	0.24	0.32	0.40	0.48	0.56	0.64	0.72
40	0.38	0.50	0.63	0.75	0.88	1.01	1.13
50	0.59	0.79	0.98	1.18	1.37	1.57	1.77
63	0.94	1.25	1.56	1.87	2.18	2.49	2.81
80	1.51	2.01	2.51	3.02	3.52	4.02	4.52
100	2.36	3.14	3.93	4.71	5.50	6.28	7.07

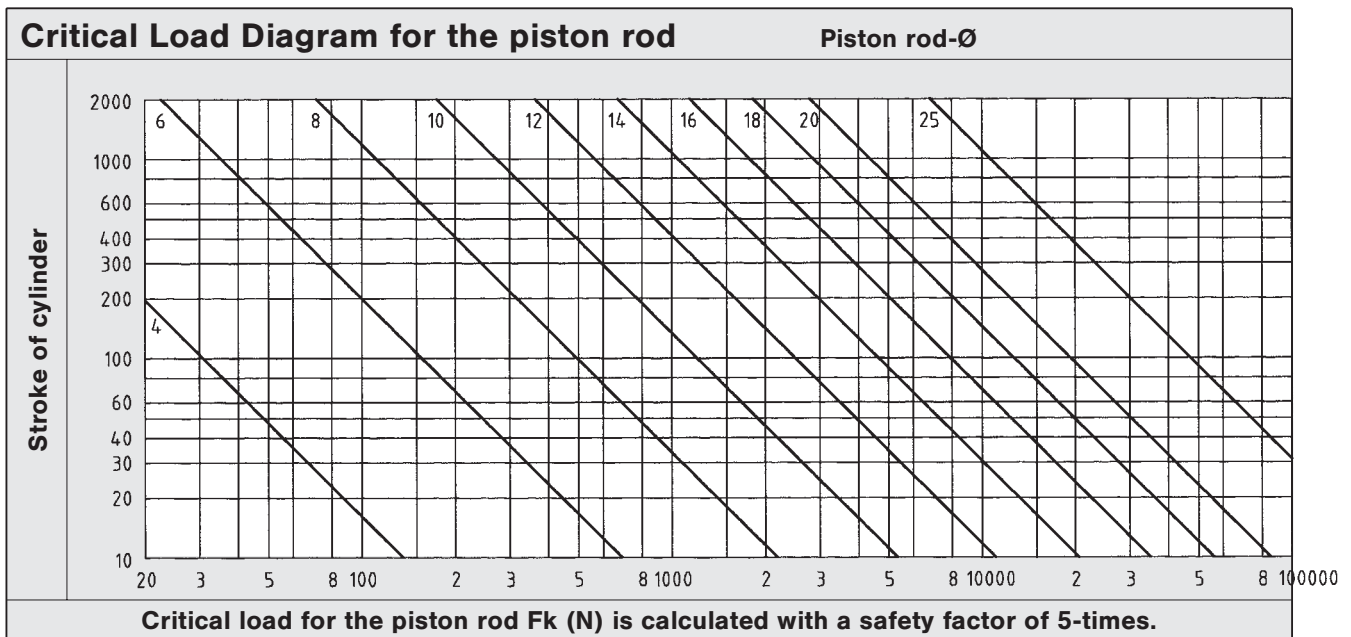

$$F_k = \frac{\pi^2 EI}{L_k^2 S}$$

$F_k$  = permitted critical force (N)  
 $E$  = elasticity module (N/mm<sup>2</sup>)  
 $I$  = moment of inertia (mm<sup>4</sup>)  
 $L_k$  = effective length of critical load  
 $S$  = security

Elastic cases of buckling according to „Euler“

