



# PLASTIC BOTTLE BLOW MOLDING AUTOMATION

## Sidel® Series1 Machines

# Blowing Station Base Mold Bushings

## ML# 305526

*Provides Significantly Longer Life - Reduces Maintenance and Downtime*

### BENEFITS

- PHD's TC fluoropolymer composite bushings directly interface with Sidel Series1 SBO machinery.
- PHD TC bushings are sealed keeping out moisture and contamination as well as retaining internal lubrication.
- TC bushing will not damage guideshaft as compared to recirculating ball bushings which can groove the guideshaft.
- TC bushing will not catastrophically fail like recirculating bushing.
- Lubrication reservoir in each bushing, extends maintenance intervals and bushing life.
- FDA approved lubrication.
- Sold in sets of two.

### FEATURES

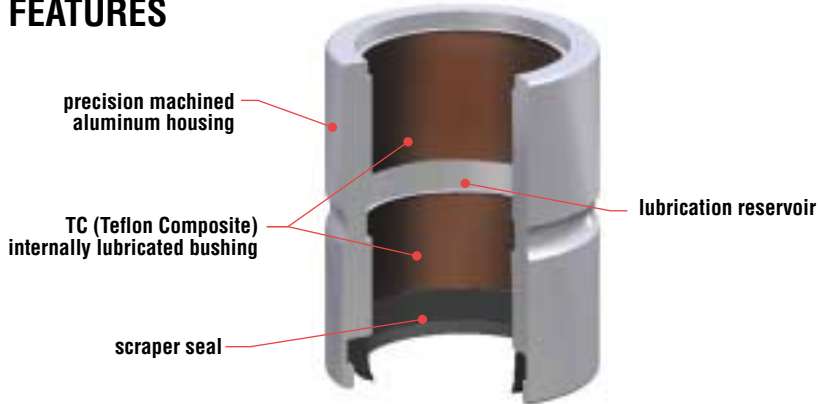

### DIMENSIONS

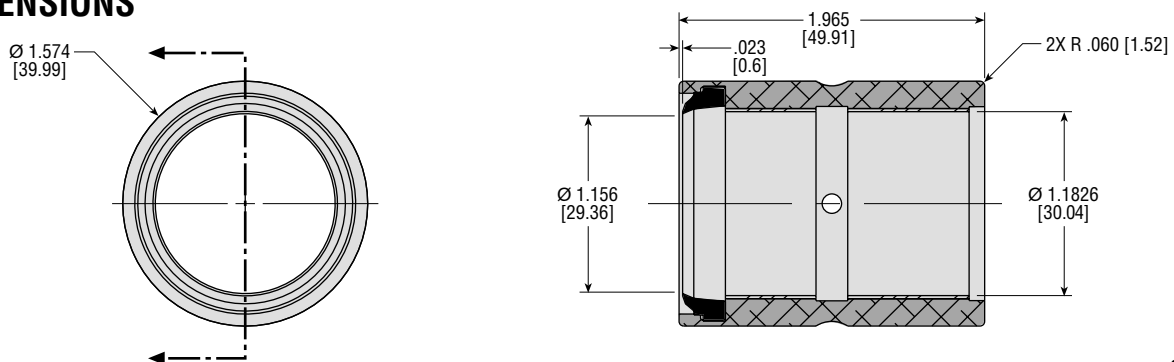

CP305526

